

, 15, 49005, ; e-mail: sobmb@i.ua

EN 12663-2:2018.

45-

EN 12663-2:2018

8

Freight car fleet renewal and the introduction of new efficient freight transportation technologies are topical problems of the Ukrainian railway transport. An innovation in the world's transport service is the use of swap-body freight cars. With seasonal variations in freight shipment, one empty car body can be replaced with another, and the undercarriage with the new body can then be used as a usual dedicated car. It is expedient for Ukraine to develop a swap-body car design of its own. In doing so, special attention must be paid to body-on-undercarriage fasteners. The goal of this paper is to estimate the stress and strain field of swap-body car components and develop recommendations on fasteners that would provide safe freight transportation in swap-body cars according to the Ukrainian State Standard EN 12663-2:2018. The paper considers a swap-body car whose undercarriage is a container flat car and whose body has the dimensions of a 45-foot container; the body mass plus the freight mass is equal to the carrying capacity of the flat car. Previous studies showed that four fitting joints in the presence of clearances therein cannot provide the required swap-body car service strength. The paper analyzes existing designs of body-on-undercarriage fasteners and identifies lines of their improvement: increasing the number of fasteners that transfer service loads from the body to the underframe and using additional grippers for clearance takeup. Finite-element models were developed to study the stress and strain field of swap-body car components at standard loads with account for different schemes of body-on-undercarriage fastening. Using them, it was shown that for the requirements of the Ukrainian State Standard EN 12663-2:2018 to be satisfied, it is sufficient to use eight body-on-undercarriage fitting fasteners with additional elements that make them clearance-free in a longitudinal direction and in a transverse direction on the outside of the underframe. The body-on-undercarriage fastening scheme that minimizes underframe stresses was identified. Recommendations were developed on fasteners that would provide safe freight transportation in swap-body cars.

Keywords: swap-body freight car, body-on-undercarriage fasteners, finite-element simulation, stress and strain field, structural strength.

© . . . , . . . , 2023

. - 2023. - 4.

2030 [1], [2]

-
-

[3] – [16].

(, , , ,)
,
)
,

-

(TransANT (flex freight system RAIL CARGO GROUP “Voestalpine”) WASCOSA) [7] – [10],
[11], (DB Cargo VTG) [14],
(KIRUNA WAGON AB) [15, 16],

-
-
-

“WASCOSA”,

(flex freight system)

1435

-
-

1520

ISO

-
-

300 [17].

[3].

-
-
-
-

[5]

[6]

“WASCOSA”,

700850 1

(. 1).

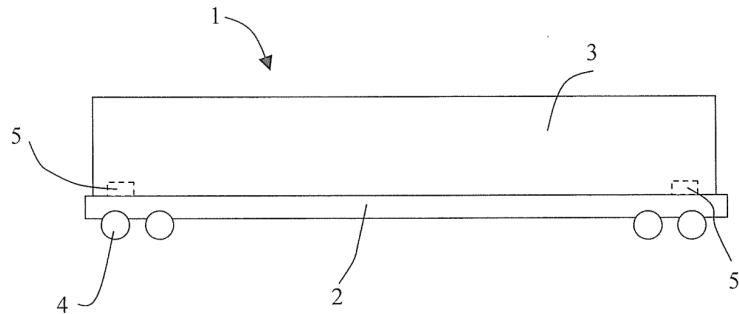

1 - ; 2 - ; 3 - ; 4 - ;
 5 -
 . 1 -

(3) (2) ,
 ,
 (3) . 1,
 (3) ,
 (3) (3) ,
 (3) (3)
 (2)
 (3) ISO. . 1 (2) (3)
 , (5),
 (3) (2)
 (3) (2)
 (3) (2)

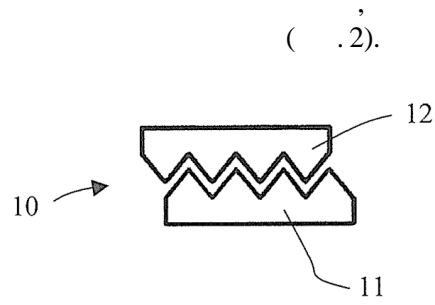
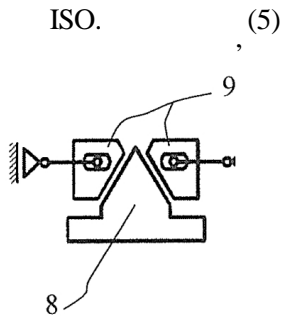

8 - ; 9 - ; 10 - ; 11 - ; 12 -) - ; 2 - (3) (2)

(3), (5), (8) (9) .2,). (3), (3), (2) (10) (.2,). (11), (12), (3), (3). (5), (2). ()

EN 12663-2:2018 [18].

7133 16 13-7133 13- [19].
 73,6 , - 16,1 . - 9700 ,
 - 14620 ,
 - 235 ,
 - 1060 .
 45- , 13400 × 2530 × 2400 .

$$m_b = 89,7 \quad - 73,6 \quad m_{ib} = 4,680$$

[18],

$$F = 2$$

[20],

.3.

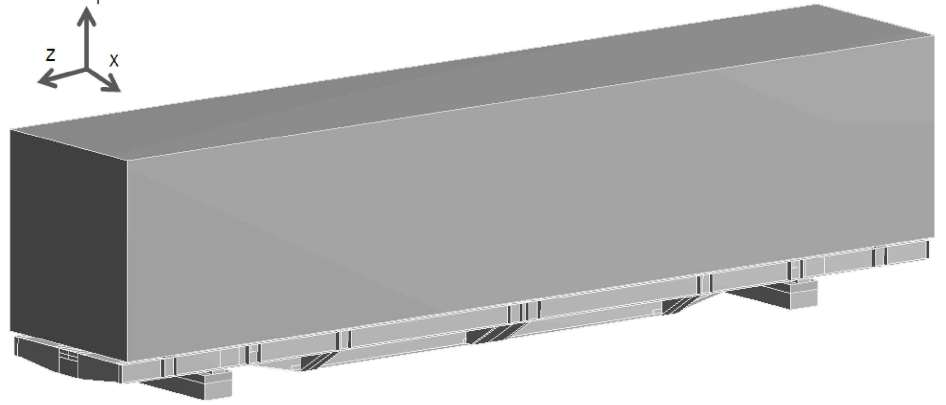
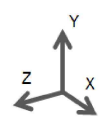

.3-

16

.4.

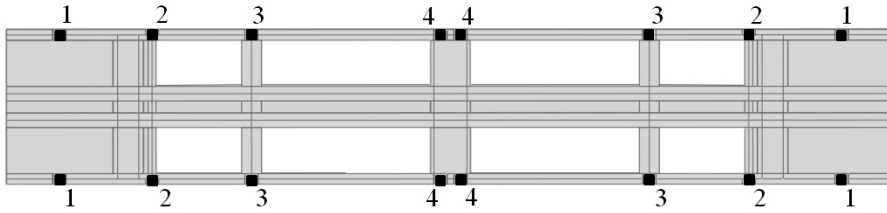

1 - 45- ;
 2 - 30- ;
 3 - 20- ;
 1 4 - 20- ;
 .4 - ()

ISO 668 1, 45-
 (4 1), 30- (4 2), 20- (3)
 20- (1 4).

(. . 4):
 1-4 ' 1;
 2-8 ' 1 3;
 3-8 ' 1 4;
 4-12 ' 1, 2, 3;
 5-12 ' 1, 3, 4;
 6-16 ' 1, 2, 3, 4.

, , x
 , , 4, ,
 4 z.
 , .
 .5.

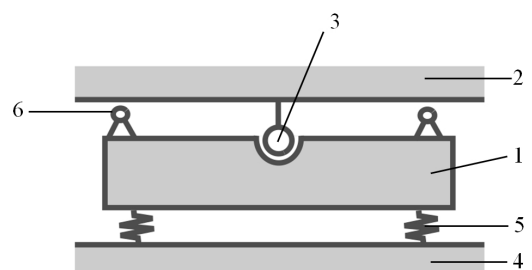

1 - ; 4 - ; 5 - ; 2 - ; 3 -
 ; 6 -
 .5 -

, , , (3).

“ - , ” (6)

.6.

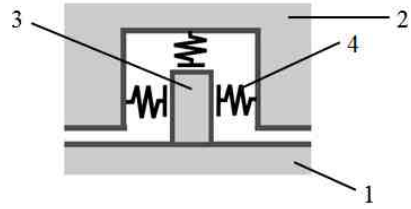

1 - ; 3 - ; 4 - ; 2 -
 .6 - ,

, (4) , -
 , " - " -
 (4) -
 .7. -
 - .8.

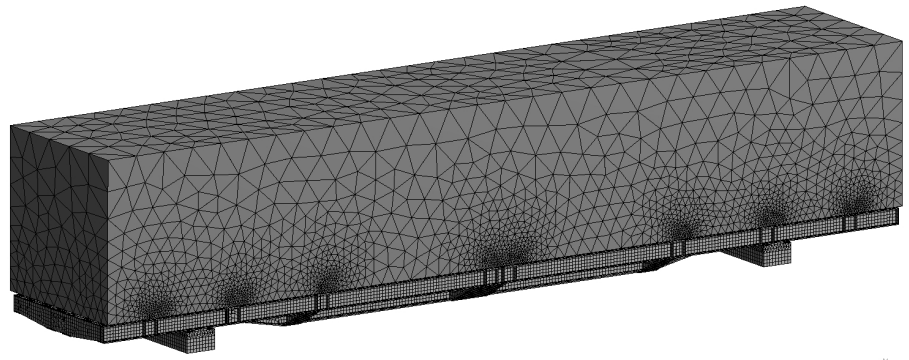

.7 - -

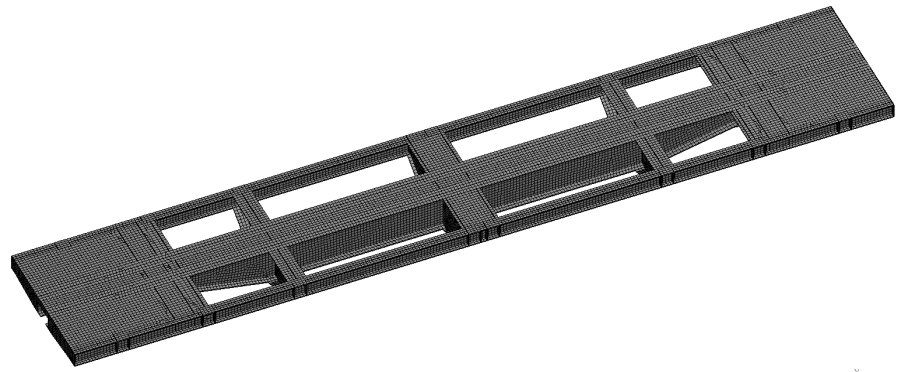

.8 - -

“ - ” 1 .
 50 , - 500 , 30 -
 313100 447265 -
 26160 26187 , -
 266651 378428 .

. 9.

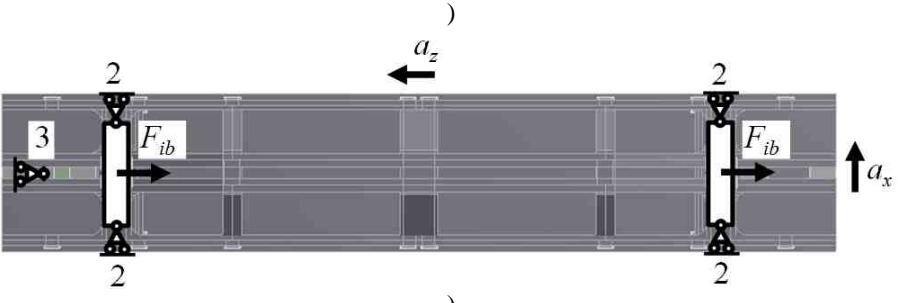
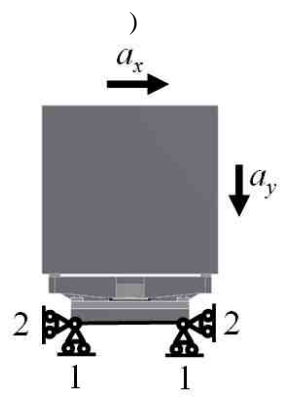
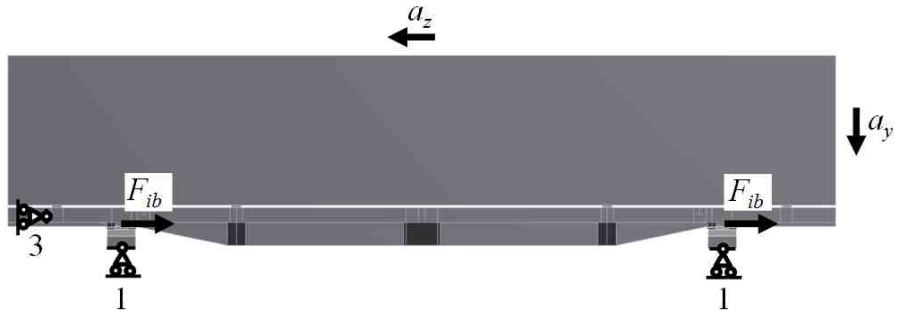

1 - ;
 2 - ;
 3 -)- ;)- ;)-
 . 9 -

a_x, a_y, a_z , F_{ib} . -
 . 1.

1		$a_x = 0; a_y = 1,3 g;$ $a_z = \frac{F}{m_b}; F_{ib} = m_{ib} \cdot a_z.$
2		$a_x = \pm 0,2 g; a_y = (1 \pm 0,3) g;$ $a_z = 0; F_{ib} = 0.$

EN 12663-2:2018

$[\sigma] = 325$, $09 \ 2$, $1:$
 $= 323$, $-\ [\sigma] = 295$. $2: [\sigma]$
 $-\ [\sigma] = 294$.

2 -

1	1	4	1	385
2	1	8	2	276
3	1	8	3	305
4	1	12	4	242
5	1	12	5	247
6	1	16	6	239
7	2	4	1	305
8	2	8	2	212
9	2	8	3	238
10	2	12	4	206
11	2	12	5	212
12	2	16	6	206

. 2

1
325 . 1 (4 ,

1)

1.

2 (7) -
 1 7 -
 . 10 - 11.

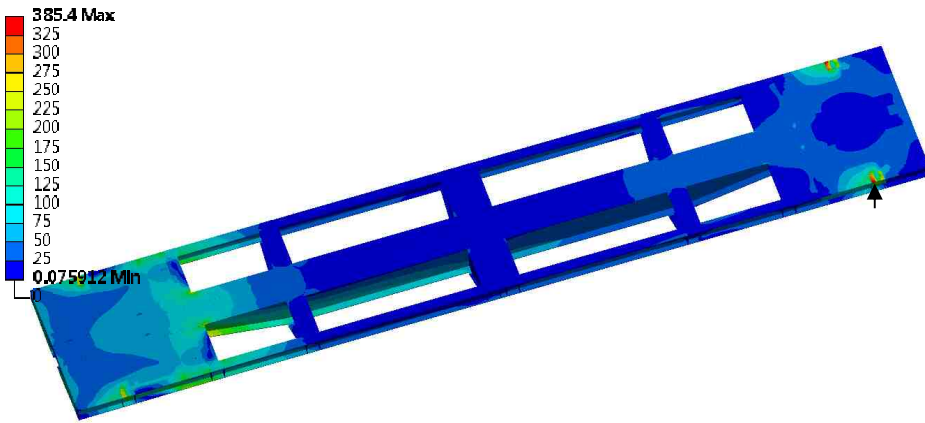

. 10 -
 (1)

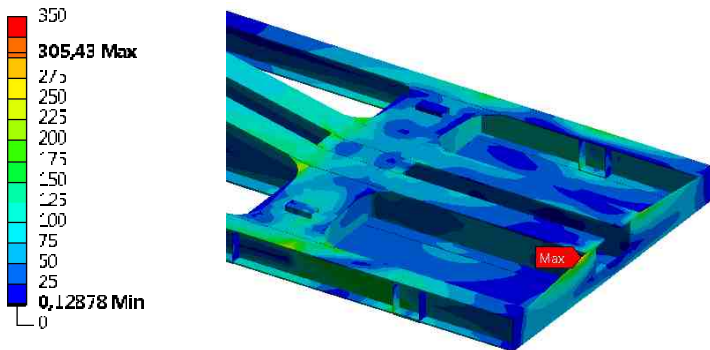

. 11 -
 (7)

. 2 (2, 8) ,
 EN 12663-2:2018 2 (8 ' ,
 1 3).
 3 (3, 9),

2, 8 . 12 - 13.

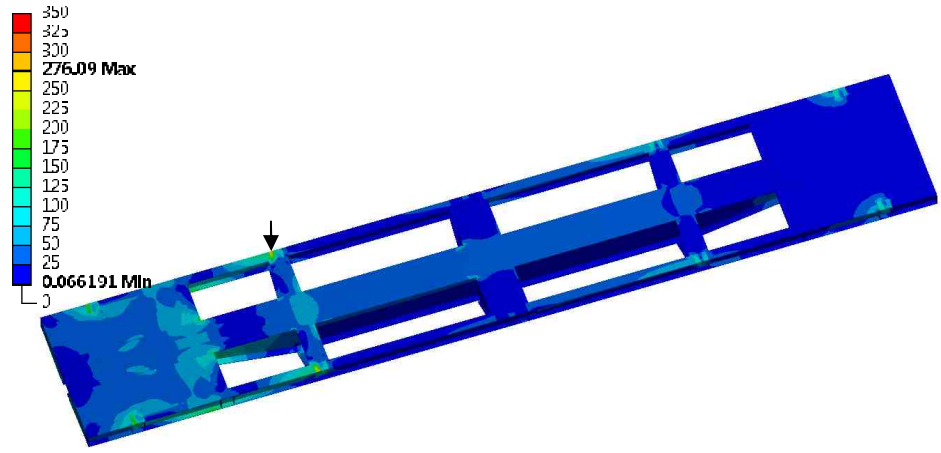

. 12 -

(2)

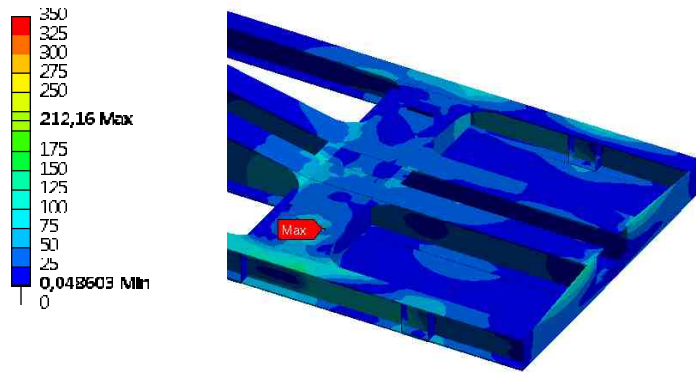

. 13 -

(8)

7598.

7598

EN 12663-2:2018,

EN 12663-2:2018).

1,75

(1

16

7598.

“WASCOSA”,

EN 12663-2:2018

73,6

8

2 (8

1 3),

16

(6)

7598;

45-

[20].

45-

73,6

EN 12663-2:2018.

EN 12663-2:2018

8

1. 2030. URL: <https://nes2030.org.ua/#rec246067109> (01.11.2023).
2. 03 2021 . 179 2030 . URL: <https://www.kmu.gov.ua/npas/pro-zatverdzhennya-nacionalnoyi-eko-a179> (01.11.2023).
3. URL: <https://wagon-cargo.ru/news/v-chem-otlichiya-i-preimushchestva-smennykh-i-semnykh-kuzovov-gruzovykh-vagonov/> (30.11.2021).
4. URL: <https://spec.rzd-partner.ru/page16921814.html> (30.11.2021).
5. URL: <http://%D0%BC%D0%BE%D1%8F%D0%BA%D0%BE%D0%BB%D0%B5%D1%8F1520%D1%80%D1%84/new/7411/> (30.11.2021).
6. URL: https://www.uniwagon.com/multimedia/media_about_us/vagony-smennymi-kuzovami/ (30.11.2021).
7. New body module for the WASCOSA flex freight system® in successful practical use []. URL: https://www.wascosa.ch/en/media/press-releases/new-body-module-for-the-wascosa-flex-freight-systemr-in-successful-practical-use_m424 (01.11.2023).
8. Innovations WASCOSA flex freight system® with timber cassette swap body. URL: https://www.wascosa.ch/wagenpark/pdf/en/innovationen/inno_wascosa_flex_freight_system_timber_swap_body.pdf (01.11.2023).
9. Innovations WASCOSA flex freight system® with E-type swap body. URL: https://www.wascosa.ch/wagenpark/pdf/en/innovationen/inno_wascosa_flex_freight_system_e_type_swap_body.pdf (01.11.2023).
10. Wascosa introduces the Wascosa flex freight system for transporting chemical products. URL: <https://tanknewsinternational.com/wascosa-introduces-the-wascosa-flex-freight-system-for-transporting-chemical-products/> (01.11.2023).
11. TransANT: URL: <https://www.railway.supply/transant-innovaczionnye-gruzovye-vagony/> (08.05.2023).
12. URL: https://logist.today/dnevnik_logista/2019-11-23/v-avstrij-izgotovlena-pervaja-partija-innovacionnyh-modulnyh-gruzovyh-vagonov/ (01.11.2023).
13. 13-9994*. URL: <http://%D0%B2%D1%80%D0%B5%D0%BC%D1%8F%D0%BE%D0%B2%D0%BA.online/view/wagons/13-9994/> (30.11.2021).

