

... , 15, 49005, ; e-mail: sobmb@i.ua

EN 12663-2:2018

45- EN 12663-2:2018

EN 12663-2:2018

45- EN 12663-2:2018

A new line in railway transportation is the use of swap-body freight cars. Their undercarriage is a flat car for swap bodies, which consists of an underframe, running gear, automatic couplers, automatic braking devices, and body fasteners. With seasonal variations in freight shipment, the same flat cars can be used because empty bodies of one purpose are detached from the flat cars and replaced with bodies of another purpose, thus making it possible to use the freight cars obtained in this way dedicated ones. The advantage of freight transportation with swap-body cars is that it allows one to reduce the car acquisition and maintenance cost due to the effective use of a flat car as the most expensive part of a freight car, avoid car demurrage caused by seasonal variations in freight shipment, and speed up the replacement of damaged bodies. It is expedient to introduce freight transportation with swap-body cars on the Ukrainian railways using the world's experience in the development of swap-body cars. This paper considers a swap-body freight car whose undercarriage is a container flat car. The goal of the paper is a mathematical simulation of the stress and strain field of the components of a swap-body freight car at standard loads according to the Ukrainian State Standard EN 12663-2:2018. Finite-element models were developed to study the stress and strain field of the components of a 45-foot container flat car and a swap-body car at standard loads with account for the features of body-on-undercarriage fastening and clearances in the fasteners. The models underlie the scientific novelty of the paper. Using them, the stress and strain field of the car components at standard loads was studied. According to the requirements of the Ukrainian State Standard EN 12663-2:2018, the strength of the structural components of the flat car underframe was estimated under different loading conditions. It was found that the strength of the 45-foot container flat car underframe under study meets requirements of the Ukrainian State Standard EN 12663-2:2018, while the strength of the underframe of the swap-body car undercarriage does not. This study evidences the need to strengthen the body-on-undercarriage fasteners and improve the design of the swap-body car underframe itself.

Keywords: swap-body freight car, body-on-undercarriage fasteners, finite-element simulation, stress and strain field, structural strength.

2030 [1, 2]

[3 – 14].

13-7133

(. 1).



. 1 – - 13-7133

- 13-7133

40- 45- 13-7133 [15]

. 1.

| | | |
|------|-------|---|
| | | |
| | 73,6 | |
| | 20,4 | |
| - | 235 | |
| | 9700 | |
| | 14620 | |
| 9238 | 0- | - |
| | 1060 | |
| | 120 | / |

ISO 668:2015 1 [16],

45- , 40-
 - 30,48 .
 , 45- , -
 13400 × 2530 × 2400 . -
 - 13-7133
 - 73,6 , 2
 45- - , -
 , - 73,6

EN 12663-2:2018 [17] 7598:2014 [18].

[17] ([18]) [17]
 ([18]). , - EN 12663-2:2018.
 [17] -

$$F = 2$$

()

EN 12663-2:2018.

45- - -
 - -
 , -
 .

[19, 20, 21].

$$\begin{aligned}
 & A\bar{\sigma} + \bar{f} = 0; \\
 & B\bar{\varepsilon} = 0; \\
 & \bar{\varepsilon} = A^T \bar{u}; \\
 & \bar{\varepsilon} = D\bar{\sigma}; \\
 & L\bar{\sigma} = \bar{p},
 \end{aligned}$$

$$\sigma_e = \frac{1}{\sqrt{2}} \sqrt{(\sigma_x - \sigma_y)^2 + (\sigma_y - \sigma_z)^2 + (\sigma_z - \sigma_x)^2 + 6(\tau_{xy}^2 + \tau_{yz}^2 + \tau_{zx}^2)},$$

$$\sigma_x, \sigma_y, \sigma_z \quad ; \quad \tau_{xy}, \tau_{yz}, \tau_{zx}$$

$$\sigma_e \quad [\sigma]$$

$$\sigma_e \leq [\sigma].$$

45-

. 2.

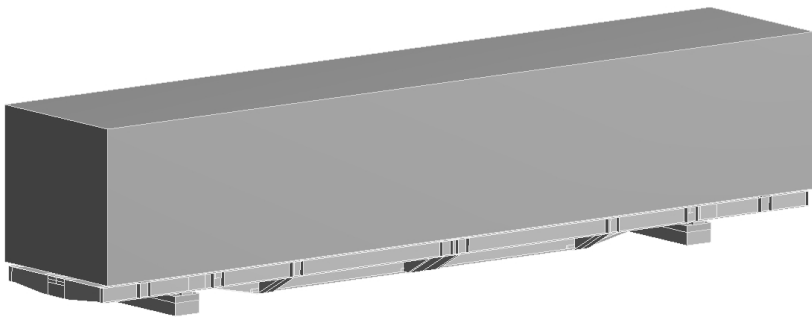

)

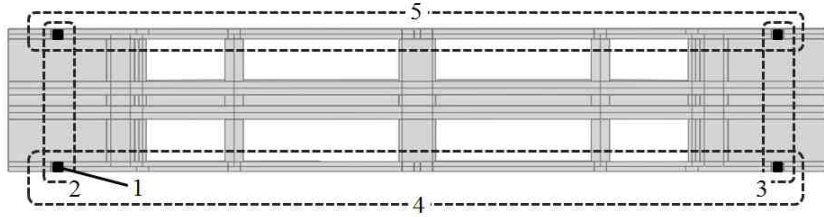

)

1 – ; 2 – ; 3 – ;
 4 – ; 5 – ;) – ;) –

. 2 – -

7055, , , : , -
 18-
 30,48 , 45-
 81,19 ³. , -
 375,4 / ³. , -
 73,6 , 939,8 / ³. , -

. 3. (1) (2) - (3). (1) -
 . 4. (1) -
 (6) , , -
 , , -
 (7) “ -
 . 5.

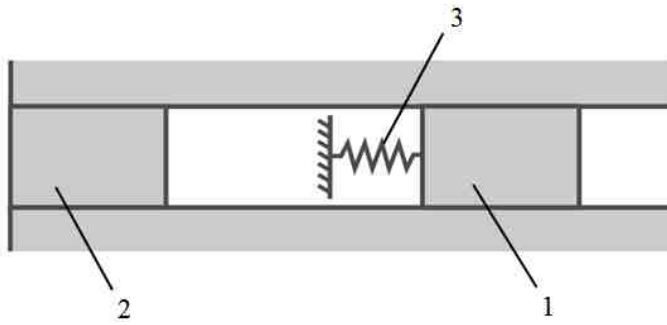

1 - ; 2 - ; 3 -

. 3 -

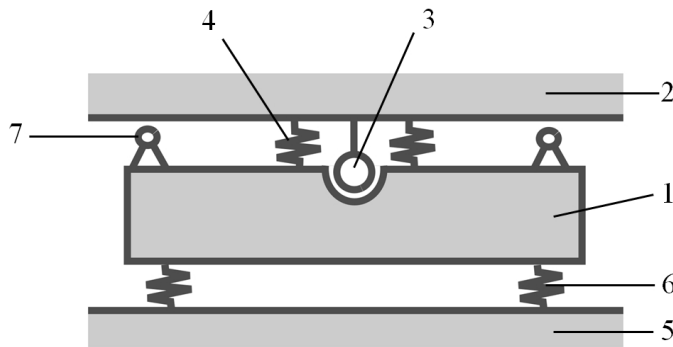

1 - ; 2 - , ;
 3, 4 - , ; 5 - ; 6 - , ; 7 -

. 4 -

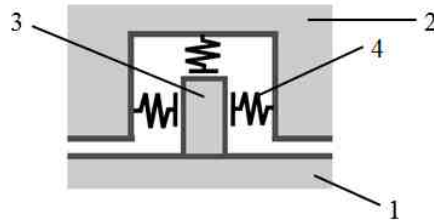

1 - ; 2 - ; 3 - ; 4 -

. 5 -

(2)

(3).

(1)

(4)

. 6 - 7.

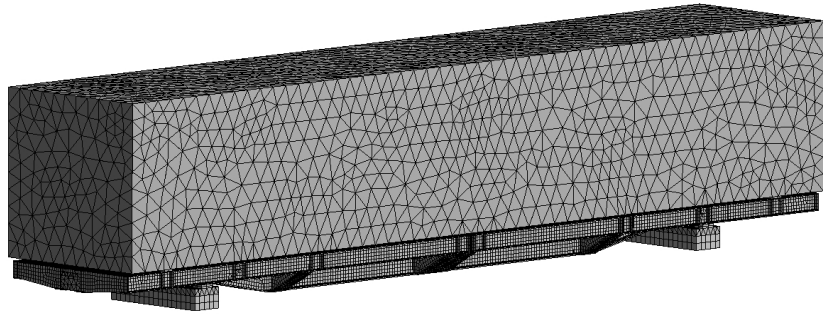

.6- - -

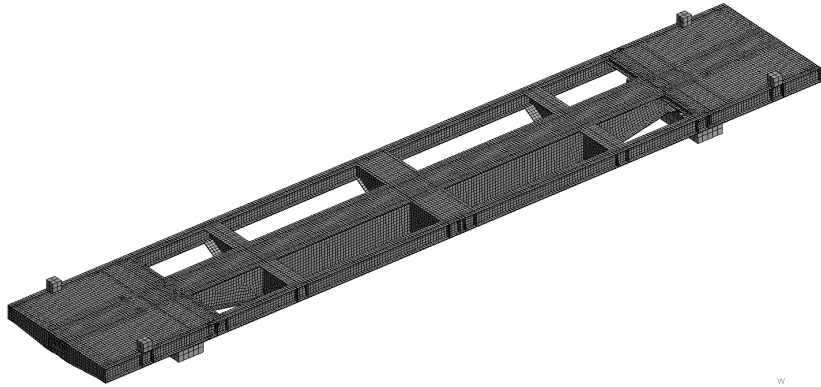

) w



)

.7- -)- ;)- - ()

-
 ,
 -
 ,
 -
 “ - ”
 1
 50 ,
 - 100 , - 75 , - 250
 108067
 147789
 29906 29887 , - 71855 103134

. 8.

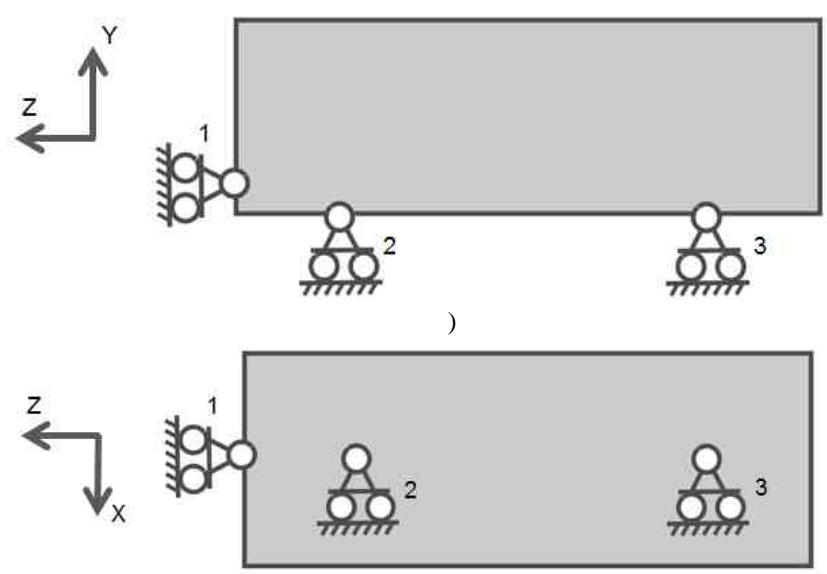

1 - ; 2, 3 -

) - ;) -

. 8 -

EN 12663-2:2018

. 2.

| | | |
|---|--|--|
| | | |
| 1 | | $a_x = 0;$ $a_y = 1,3 g;$ $a_z = \frac{F}{m_b}.$ |
| 2 | | $a_x = \pm 0,2 g;$ $a_y = (1 \pm 0,3) g;$ $a_z = 0.$ |

- 89,7 . 16,1 , 1 73,6 .
 $a_z = \frac{F}{m_b} = 22,3 / ^2.$
 2 $a_x = 0,2 g ,$
 - , $a_y = 1,3 g ,$

EN 12663-2:2018

EN 12663-2: 2018,

. 3.

| | | |
|--|-----|--|
| | | |
| | 2 g | |
| | 1 g | |
| | 2 g | |
| | 1 g | |

1 - 2 g .

)

.4.

4-

EN 12663-2:2018

1

| | | |
|--|-----------------------------------|-------------------------|
| | | $[\sigma] = [\sigma]$, |
| | $R_p < 0,8 R_m$ | R_p |
| | $R_p > 0,8 R_m \quad A_e > 10 \%$ | R_p |
| | $R_p > 0,8 R_m \quad A_e < 10 \%$ | $\frac{R_m}{1,25}$ |
| | $R_p < 0,8 R_m$ | $\frac{R_p}{1,1}$ |
| | $R_p > 0,8 R_m \quad A_e > 10 \%$ | $\frac{R_p}{1,1}$ |
| | $R_p > 0,8 R_m \quad A_e < 10 \%$ | $\frac{R_m}{1,375}$ |

.4

- R_p -

- R_m -

- A_e -

- $[\sigma]$ -

1

09 2 .

$R_p < 0,8 R_m$,

.4

- $[\sigma] = 295$

$[\sigma] = 325$,

2

EN 12663-2:2018

$[\sigma] = \sigma_{\max \text{ lim}} ;$

$\sigma_{\max \text{ lim}} = \text{MIN}(\sigma_{\text{Alim}} \cdot (1 + K) / K ; [\sigma]) ;$

$\sigma_{\text{Alim}} = (0,46 \cdot R_p) / 2 ,$

σ_{Alim} -

; K -

$\sigma_{\max \text{ lim}}$

1.

, $\sigma_{\max \text{ lim}}$

09 2

.5.

| | [σ], | | | | |
|-------------|--------------|-----|-----|-----|-----|
| | 1 | 2 | 3 | 4 | 5 |
| 09 2 325 | 323 (294) | 195 | 173 | 143 | 117 |

.1 – (); 2 –
; 3 – ; 4 – ;
5 – .

EN 12663-2:2018,

45- , 30,48 ,
73,6
(.6. .2). EN 12663-2:2018
(. .2,)).
6 –

| | | | | |
|--------------|---|---|---|--|
| | | | | |
| 45- 30,48 | 1 | 1 | 1 | |
| | 2 | 1 | 2 | |
| | 3 | 2 | 3 | |
| | 4 | 2 | 4 | |
| 73,6 | 5 | 1 | 1 | |
| | 6 | 1 | 2 | |
| | 7 | 2 | 3 | |
| | 8 | 2 | 4 | |

.9 – 10

(5).

.7.

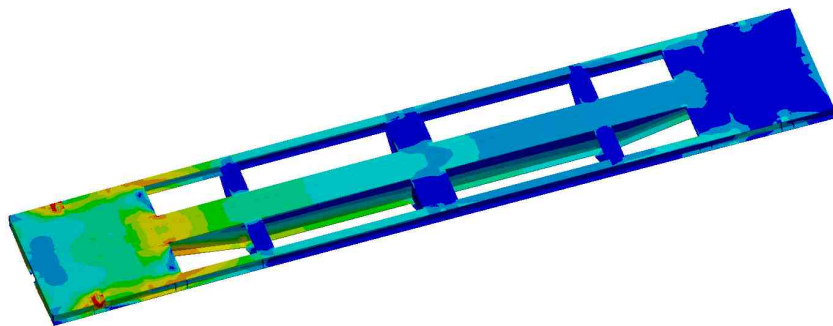
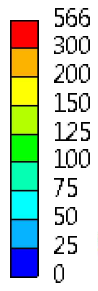

)

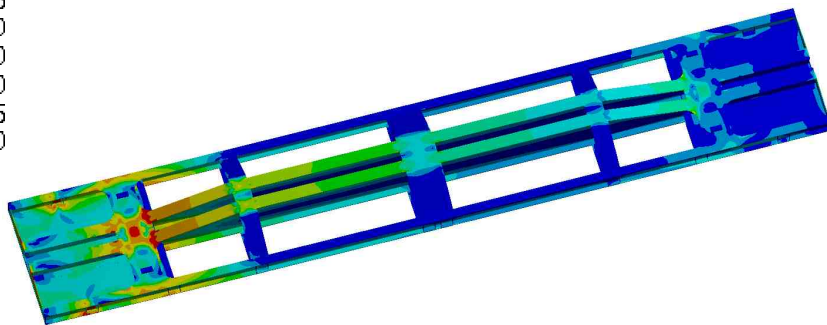
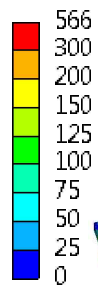

)

)- ;)-

.9 -

(5)

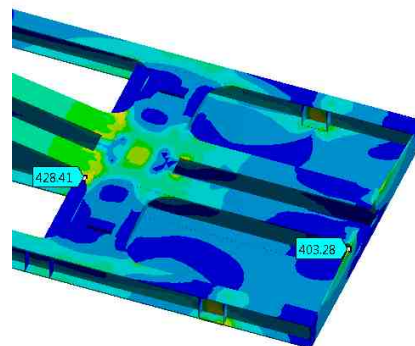
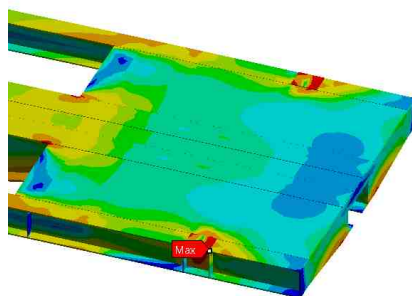
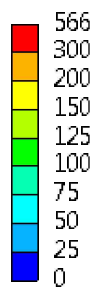

)

)

)-
)-

;

.10 -

(5)

| | | | |
|---|--------------|---|------|
| - | 45- 30,48 | | 73,6 |
| | , | | , |
| 1 | 207 | 5 | 567 |
| 2 | 225 | 6 | 620 |
| 3 | 132 | 7 | 329 |
| 4 | 134 | 8 | 309 |

, -
 - (1 - 2)
 , . 3 - 4
 . 1 - 4
 -
 EN 12663-2:2018.
 (5 - 6) , -
 , -
 . 7 8 -
 , -
 -
 45- -
 .7, -
 - 45- (1 - 4), -
 , -
 (5 - 7) , -
 EN 12663-2:2018. -
 . -
 , -
 . -
 - 45- -
 , -
 . -
 - -
 . -

1. 2030. URL: <https://nes2030.org.ua/#rec246067109> (08.05.2023).
2. 03 2021 . 179 2030 . URL: <https://www.kmu.gov.ua/npas/pro-zatverdzhennya-nacionalnoyi-eko-a179> (08.05.2023).
3. . URL: <https://wagon-cargo.ru/news/v-chem-otlichiya-i-preimushchestva-smennykh-i-semnykh-kuzovov-gruzovykh-vagonov/> (30.11.2021).
4. . URL: <https://spec.rzd-partner.ru/page16921814.html> (30.11.2021).
5. . URL: <http://%D0%BC%D0%BE%D1%8F%D0%BA%D0%BE%D0%BB%D0%B5%D1%8F1520.%D1%80%D1%84/new/7411/> (30.11.2021).
6. . URL: https://www.uniwagon.com/multimedia/media_about_us/vagony-so-smennymi-kuzovami/ (30.11.2021).
7. SECU-Box for Better utilization of Load Capacity. Advantage Environment – 2009. URL: <http://advantage-environment.com> (08.05.2023).
8. Innofreight. InnoWaggon – No base, no go. URL: <https://www.innofreight.com/en/logistics-solutions/inno-waggon/> (08.05.2023).
9. Innovations WASCOSA flex freight system® with timber cassette swap body. URL: https://www.wascosa.ch/wagenpark/pdf/en/innovationen/inno_wascosa_flex_freight_system_timber_swap_body.pdf (08.05.2023).
10. Innovations WASCOSA flex freight system® with E-type swap body. URL: https://www.wascosa.ch/wagenpark/pdf/en/innovationen/inno_wascosa_flex_freight_system_e_type_swap_body.pdf (08.05.2023).
11. Wascosa introduces the Wascosa flex freight system for transporting chemical products. URL: <https://tanknewsinternational.com/wascosa-introduces-the-wascosa-flex-freight-system-for-transporting-chemical-products/> (08.05.2023).
12. TransANT: . URL: <https://www.railway.supply/transant-innovaczionnye-gruzovye-vagony/> (08.05.2023).
13. . URL: https://logist.today/dnevnik_logista/2019-11-23/v-avstrii-izgotovlena-pervaja-partija-innovacionnyh-modulnyh-gruzovyh-vagonov/ (08.05.2023).
14. 13-9994*. URL: <http://%D0%B2%D1%80%D0%B5%D0%BC%D1%8F%D0%BE%D0%B2%D0%BA.online/view/wagons/13-9994/> (30.11.2021).
15. “ ”. 13-7133 13-7133-01. URL: <https://www.kvsz.com/index.php/ua/produktsiya/vantazhne-vagonobuduvan-nya/vagoni-platформи/item/2415-vahon-platforma-model-13-7133-i-13-7133-01> (08.05.2023).
16. ISO 668:2015 (ISO 668:2013, IDT) 1. . URL: <http://csm.kiev.ua/nd/nd.php?b=1&l=3776> (08.05.2023).
17. EN 12663-2:2018 (EN 12663-2:2010, IDT) 2. . URL: http://online.budstandart.com/ua/catalog/doc-page?id_doc=81572 (08.05.2023).
18. 7598:2014 1520 (). URL: http://online.budstandart.com/ua/catalog/doc-page.html?id_doc=73763 (08.05.2023).
19. 1975. 541
20. 1990. 400 .
21. . . Ansys 2003. 272 .

16.05.2023,
24.05.2023