

. . . , . . . , . . . , . . . , . . . , . . .

1910

1910

The paper presents information about sound suppressors for small arms using spherical baffles. Data on patented products of this type are reported, beginning in 1910, when the sound suppressor design with such basic essential features was first patented. The design of patented sound suppressors and special features of their operation in accordance with inventors' description are considered in an orderly sequence.

Information about the test sound suppressor with spherical baffles developed by the authors and the results of the analysis of publications considering special features of gas dynamic processes in the sound suppressor are presented.

A standard design and the operation of the sound suppressor with spherical baffles are described. The authors filed a patent application for this design.

Conclusions relative to studies performed and the results obtained are reached and ways of further investigations are directed.

:

©

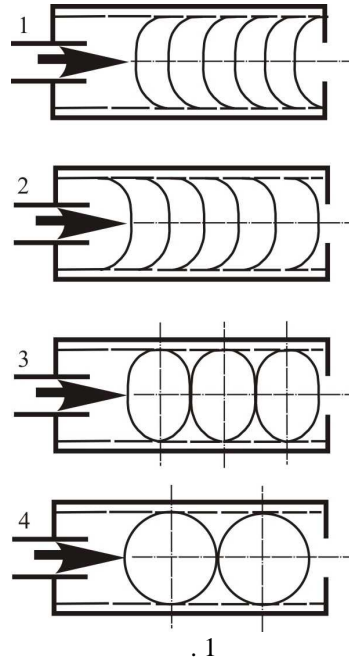

(
).
.1.

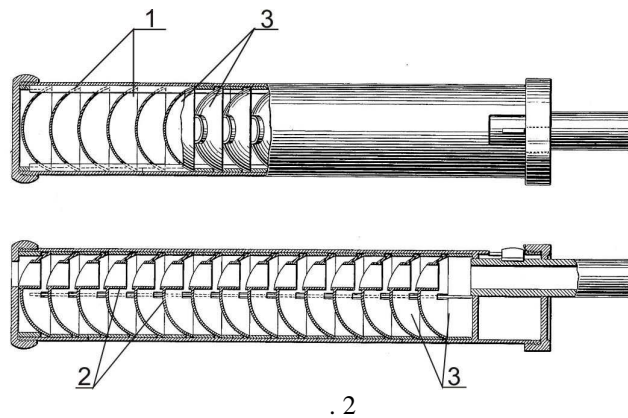

(.1.1),
(.1.2),
(.1.3) (.1.4).

24.05.1910 , J. H. Stinson [1] (959.400 .2).

1,
,
2,
3,

:«

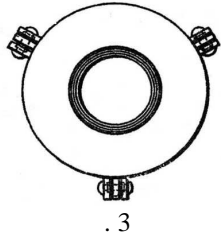
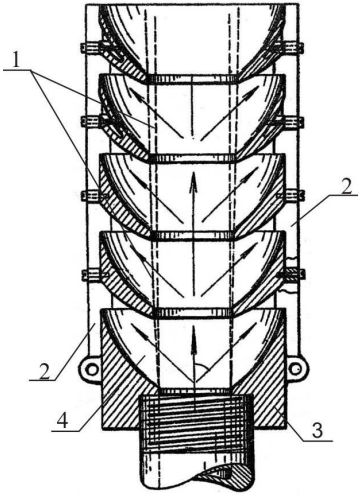

1.854.974
29.11.1930 [2] (.3)

» [1].

1,

2.

3

4

2

.3

2013/160330 1) (.4) [3].

/ 2013/058451 24.04.2012 (WO

(.3 .4.)

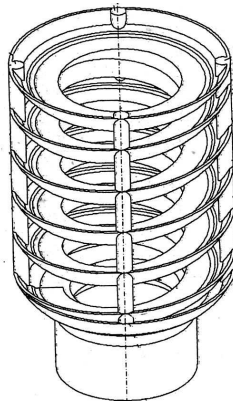
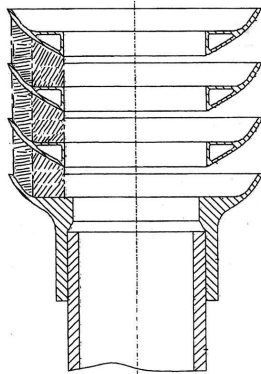

.4

5

(.5) [4]

1,

«

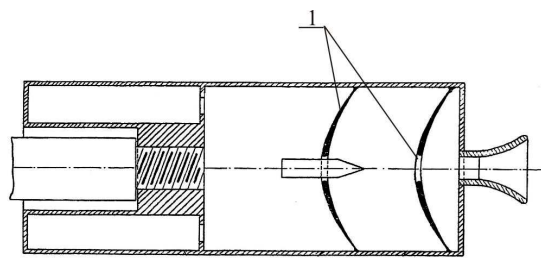

.5

».

) (, (),

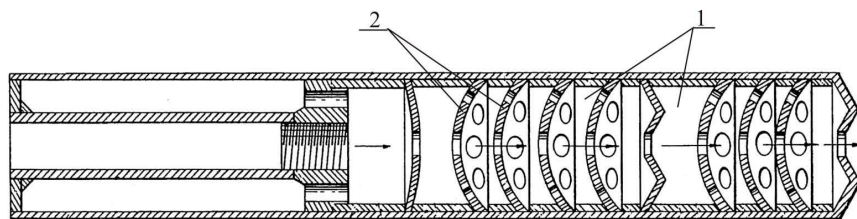

.6

4.907.488

29.03.1988 [5] (.6).

1

2 (),

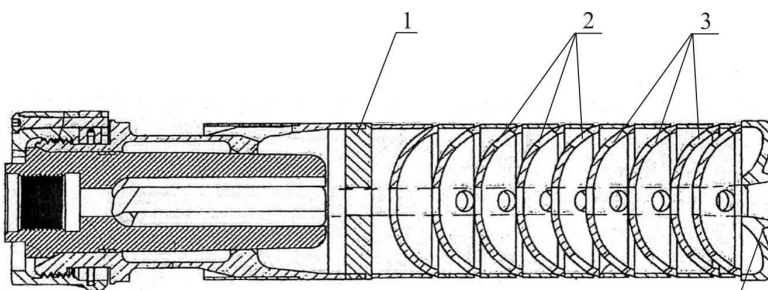

.7

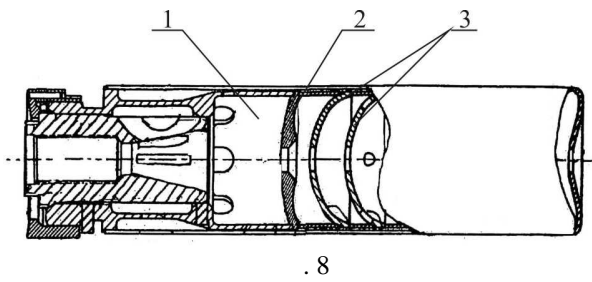

. 8

2615 403 2 (

1315 04243 07.01.2013) (. 7) [6].

1, 2, 3, 4,

(pub. us.2007/0266 844A1)

26.02.2007 [7] (. 8).

1, 2, 3.

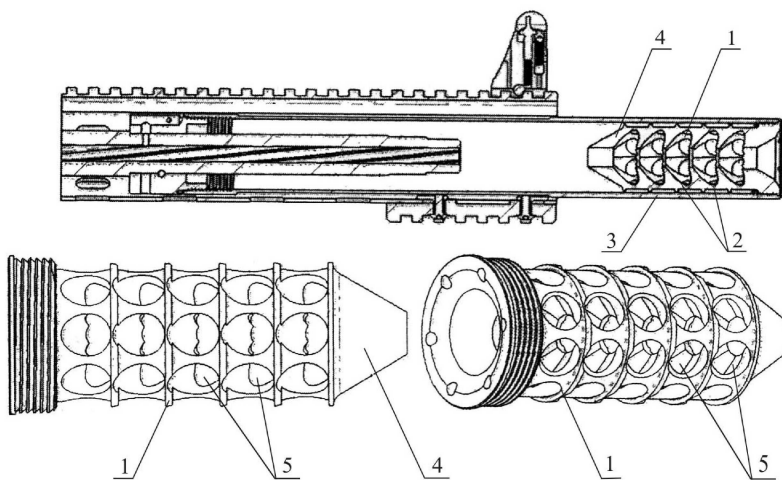

. 9

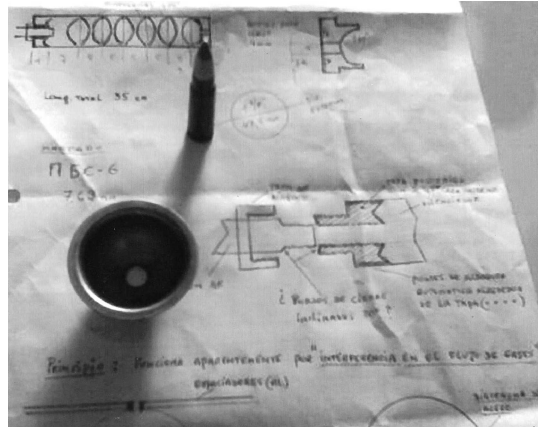

. 10

1,
2,
3.
4
,
,
5.
()

[9].

- -6 (

)(.10) [9].

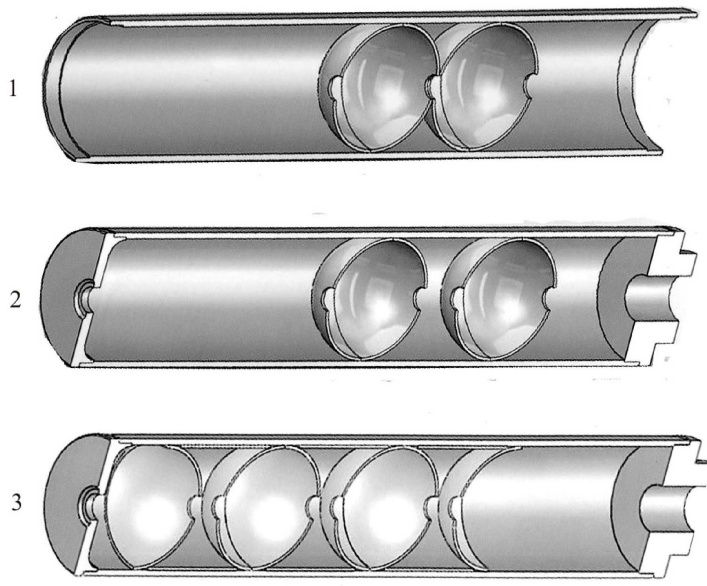

. 11

. 11 [9]

: 25 – 30

25 – 30

() ,

() .

[10].

$$X_p = C_x(q_\infty S_{mid})$$

C_x –

q_∞ –

S_{mid} –

2.3.3. 2.3.5

(≤ 1)

– 7 – 8

60 – 90° ,

[11].

0,4 – 0,5

1,2

0,1

12

30°.

[12 – 23].

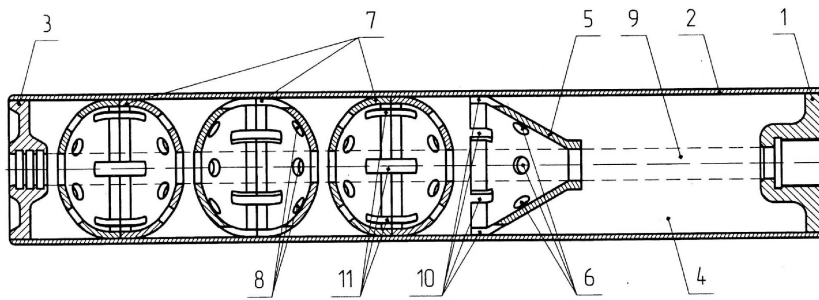

. 13

. 13

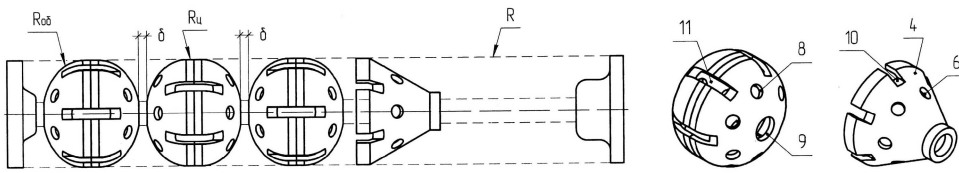

. 14

. 14

1,
3,

4
5,

2 R ,

6,

$\delta = 0,4 - 0,5$

7,

$R_{06} = 1,2R$,

R_u R ,

11

8,

9.

10 11,
30°.

1

4

(.15),

4 (.13).

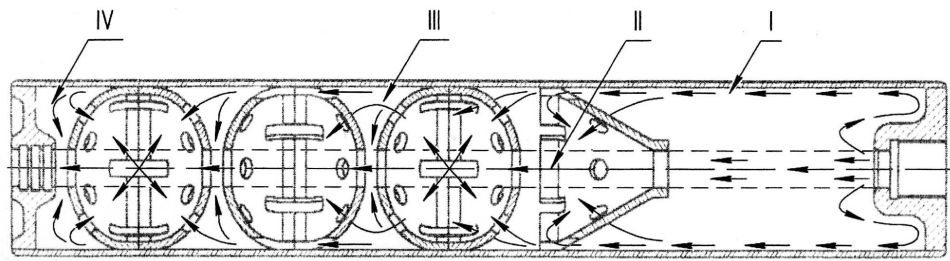

.15

(-).

.15,

: - -

V

10 11 (.13)

(. 16)

5,45; 5,56 7,62

36



. 16

[24].

1. Patent 959400 USA, Int. Cl. F41A21/30. Gun Muffler / *Janus Henry Stinsan*. – 503830 ; Filed : 23.06.1909 ; Pub. Date : 24.05.1910. – 3 p.
2. Patent 1854974 USA, Int. Cl. F41A21/30, F41A21/00. Silence / *Samuel Bernat*. – 505382 ; Filed : 29.12.1930 ; Pub. Date : 19.04.1932. – 3 p.
3. Patent 2013/160330 A1 World Patent, Int. Cl. F41A21/30. Attentuatears de bruit pur mortier / *Destuz Anne, Hubert Vincent, Salignon Denis*. – / 201305845 ; Filed : 24.04.2013 ; Pub. Date : 31.10.2013.
4. Patent 864735 France, Int. Cl. F41A21/30. Dispositif silencieux et anti-flammes posis armes a feu / *M. Edouard Pister*. – Filed : 10.04.1940 ; Pub. Date : 03.05.1941. – 6 p.

13

5. Patent 4907488 USA, Int. Cl. F41F17/12. Device for Silencing Firearms and Cannon / *Oswald F. Seberger*. – 175039 ; Filed : 29.03.1988 ; Pub. Date : 13.03.1990. – 7 p.
6. Patent 2615403 A2 European, Int. Cl. F41A21/30, F41A21/32, F41A21/34. Mounting Apparatus for Firearm Sound Suppressor / *Dueck Barry W.* – 13150424 ; Filed : 07.01.2013 ; Pub. Date : 17.07.2013, Bulletin 2013/29. – 30 p.
7. Patent 2007/0266844 A1 USA, Int. Cl. F41A21/30. Sound Suppressors for Firearms / *Barry W. Dueck*. – US 11/711430 ; Filed : 26.02.2007 ; Pub. Date : 22.11.2007. – 7 p.
8. Patent 2014/120401A2 World Patent, F41A21/30. Suppressors Assembly for a Firearm / *Daniel, Marvin C., Thompson, Dewayne Lee.* – /US 2014/010668 ; Filed : 08.01.2014 ; Pub. Date : 07.08.2014.
9. () (10.06.2009) []. – : <http://www.silencertalk.com/forum/viewtopic.php?1=40014>.
10. : / . . . , 1981. – 496 .
11. // – 2011. – 1. – . 86 – 98.
12. // – 1999. – 1. – . 13 – 17.
13. // – 2005. – 1. – . 77 – 88.
14. // – 2007. – 2. – . 142 – 150.
15. // – 2009. – 2 (59). – . 53 – 61.
16. : X , 2009. – . 474 – 477.
17. [(CD-ROM). – 66, 10 . – ISBN 978-5-9902974-1-8 – 0321101669. 98164 , G01M 9/00, F41A 21/30. / . . . ; . – a 2010 04890 ; . 23.04.2010 ; . 25.04.2012, . 8. – 6 .
18. // 2012. – 4. – . 13 – 26.
19. // – 1990. – 3. – . 152.
20. // – 1994. – 1. – . 158 – 165.
21. // . – 2001. – . 42, 4. – . 52 – 61.
22. // . – 1987. – . 2370. – . 13 – 20.
23. 201410885 , F41 21/30. / . . . ; . – 06.10.2014.

18.11.14,
15.01.15